

BKT
mobiliario
urbano

Ficha Técnica
Product Sheet

DOG-005

Aro de Brinco Jump Ring



DOG-005



Aro de Brinco Jump Ring

Incluir a todo tipo de usuarios es uno de nuestros propósitos, por lo que diseñamos también para las mascotas al formar una parte importante de nuestra familia. Puede resistir cualquier condición climática con sus debidos tratamientos. Disponible en una variedad de colores para poder integrarse perfectamente a diversos entornos.

Including a variety of users for our products is one of our purposes, that's why we design for the pets since they take an important role in our families. Can withstand any weather conditions with the adequate material treatments. Available in a variety of colors to seamlessly blend into various spaces.

Peso: 7 kg

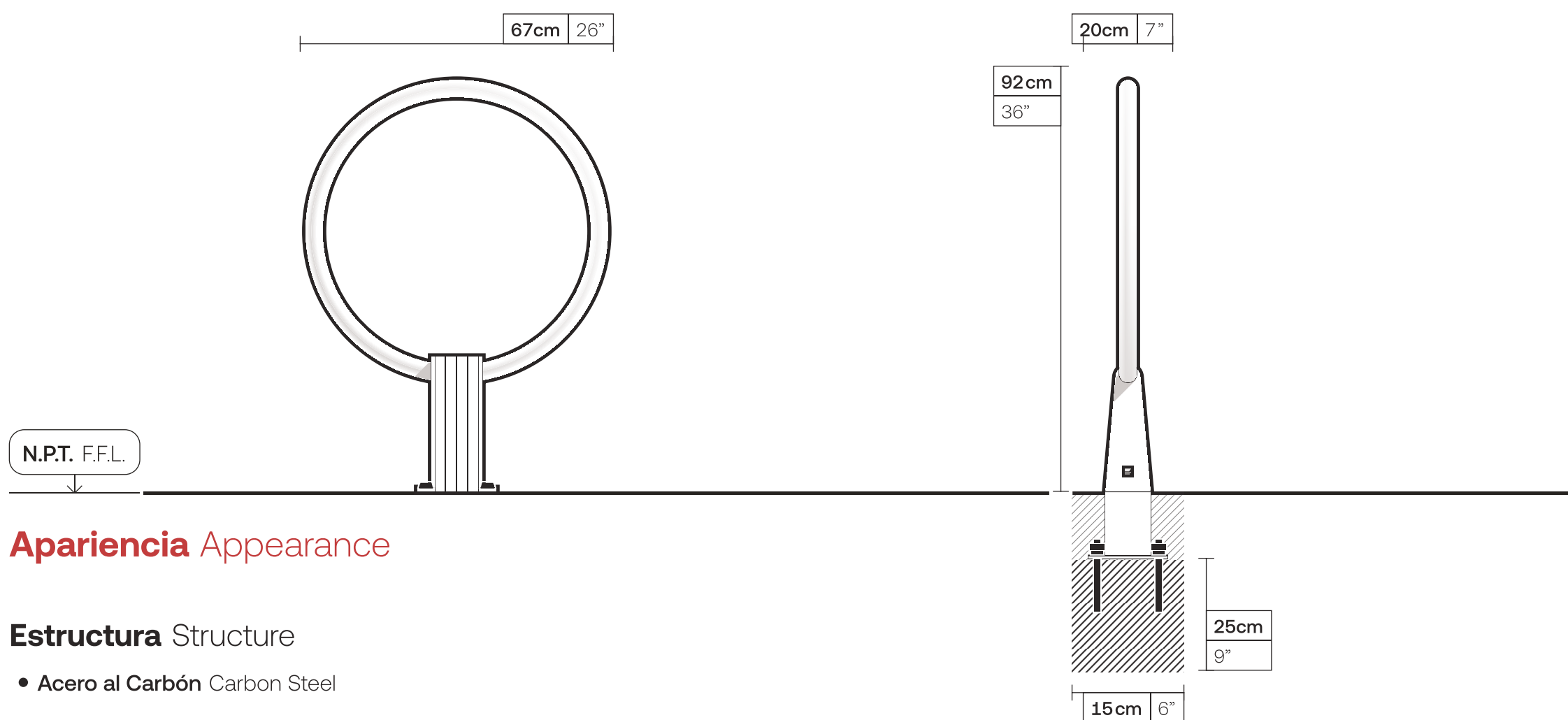

Apariencia Appearance

Estructura Structure

- Acero al Carbón Carbon Steel

Configuraciones Settings

Tamaños Sizes

- Único Default

Instalación Installation

- Taqueteable Fastened
- Ahogado Drowned

Para más información sobre las garantías, encuentralas en nuestro sitio web.

For more information about the warranties, find them on our website.

Garantías

Guarantees



Zona Urbana

Urban Area

Se refiere a zonas de baja polución, secas y frías, de baja humedad o algunas zonas desérticas.

It refers to areas of low pollution, dry and cold, low humidity or some desert areas.



Brisa Marina

Sea Breeze

Se refiere a embarcaderos o malecones con brisa de un grado muy alto de salinidad y neblina marina.

It refers to piers or promenades with very high levels of salt fog.



Alta Humedad

High Humidity

Se refiere a zonas húmedas sin niebla salina o con grado medio de salinidad con cercanía a la costa.

It refers to humid areas without salt fog or with a medium degree of salinity close to the coast.

Acero al Carbón

Carbon Steel



 60 meses months

 12 meses months



 [bkt_mobiliario.urbano](https://www.instagram.com/bkt_mobiliario.urbano)

[bktmobiliario.com](https://www.bktmobiliario.com)

 Herrera y Cairo 980
Col. Jesús 44200
Guadalajara, Jal. MX

 MiBici GDL-10
 L1, Estación Refugio

 +52 33 3825 7333
+52 33 3165 8582

 info@bktmobiliario.com